



GEISMAR®



**Measurement and verification
equipment for railways**

GEMS
GEISMAR MEASURING SYSTEMS



GEMS

GEISMAR MEASURING SYSTEMS

➤ A comprehensive range for the measuring and verification of railways

With proven experience in measurement, Geismar offers a wide range of reliable and precision equipment adapted to all types of work.

From track and turnout gauges to rail wear monitoring, the GEMS range of measuring equipment benefits from decades of innovation ensuring that tracks are fully compliant with all standards and without compromise to safety.



> Tailor-made services

Since accuracy is crucial, it is essential to guarantee that the equipment is always operational and perfectly calibrated. This is why Geismar offers its customers services specifically dedicated to measuring equipment, thus guaranteeing reliable readings in all circumstances.

Through preventive and corrective maintenance services as well as our calibration laboratories, Geismar's customer service ensures you continuous support throughout the service life of your equipment.



> The various types of instruments

From lightweight hand-held tools to rail-towed inspection vehicles, our icons easily identify the type of each instrument in the product catalogue.



Portable
positioning tool



Hand-push
trolley



Towed trolley

> Measurement segmentation

Track geometry

Measurement criteria linking both rail tracks

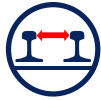

Track gauge
Distance between the two rails



Switch
Distance other than gauge between the two rails



Elevation, cant, cross-level
Inclination of track



Twist
Elevation (track twisting) over a given distance



Versine
Variation in gauge between the two rails relative to a reference



Horizontal versine, horizontal alignment
Variation in horizontal position of track over a specified distance

Rail geometry

Measurement criteria that can be measured independently from one rail to the other



Rail straightness
Alignment measurement and verification of a weld between two rails



Rail corrugation measurement



Rail inclination



Vertical versine
Variation in height along the length of a rail over a specified distance

Gauge & structure

Measurement criteria surrounding the track



Platform height



Clearance measurement

> Summary

1 | Track geometry

RCFF	Combined gauge for track gauge and level measurement	6
RCA	Combined track and turnout gauge for cant and gauge measurement	8
Garnet-DL	Digital track gauge for track and switch geometry measurement	10
Amber	Manual track recording unit	12
Amber-T	Track geometry and versine measuring and recording	14
Topaz	Track geometry and versine digital measuring and recording trolley	16
Diamond-S2	Portable track geometry & switch geometry digital measuring and recording trolley	18
Emerald	Towed track recording unit.....	20

2 | Rail geometry

Opal Mini	Laser alignment system	22
Rectirail DL2	Portable electronic straightness measurer	24
Jet	Rail inclination gauge.....	26

3 | Gauge & structure

Mephisto	Laser survey recorder	28
-----------------	-----------------------------	----

RCFF

COMBINED GAUGE FOR TRACK GAUGE
AND LEVEL MEASUREMENT

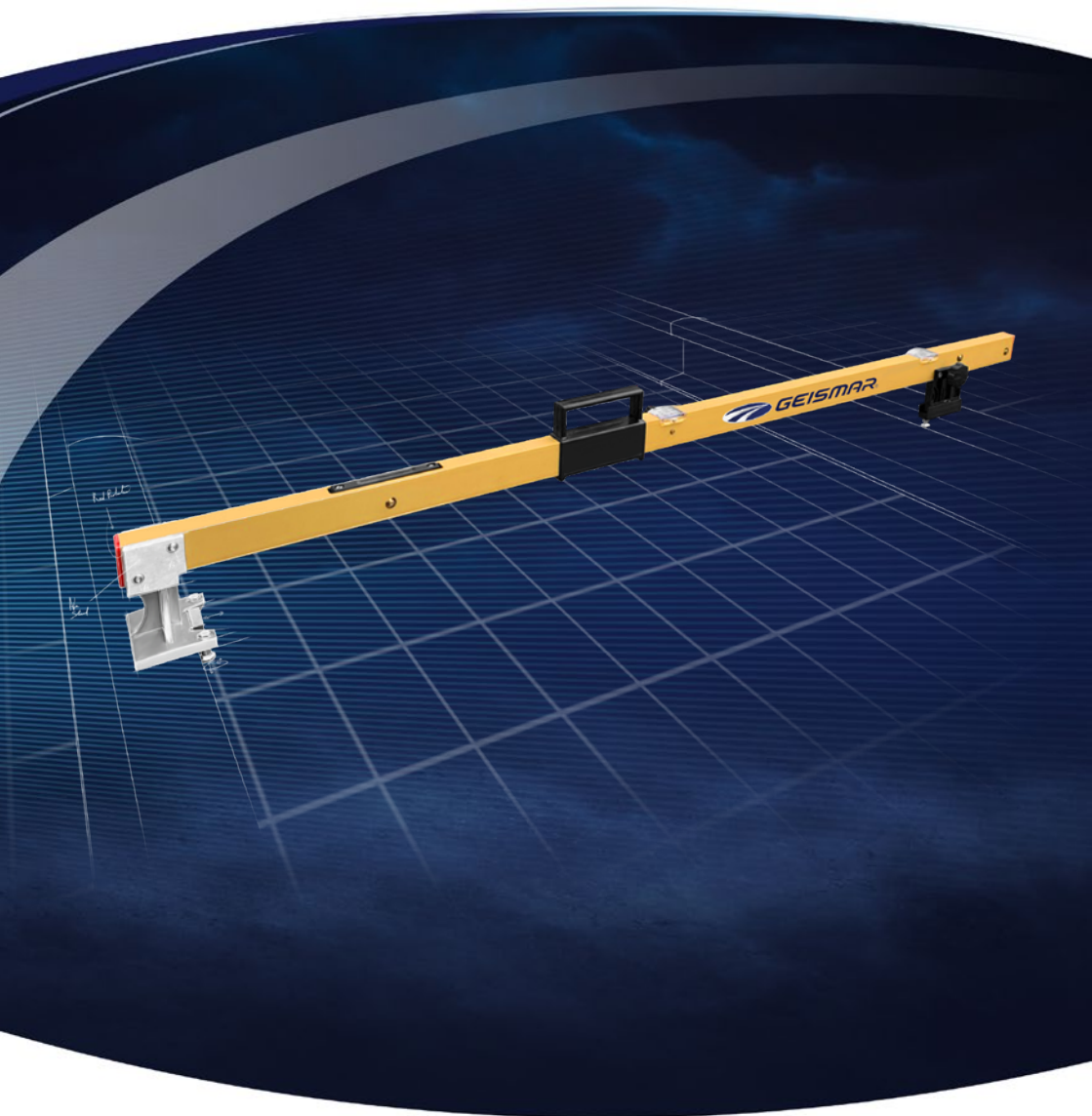

Your benefits

- Static and instantaneous measurement of the track gauge and cross-level
- Robust and lightweight gauge for intensive use thanks to its aluminium square section and the graduated protective screen
- Easy to use thanks to knurled button and adjusting screws
- Ergonomical thanks to the handle that is aligned with the gravity center

Specifications

Product details	Dedicated for plain track
Track gauge	Available for all gauges and all types of turnout
Dimensions (L x W x H)	64 x 3.9 x 6.5 in. (1,635 x 100 x 165 mm)
Mass	5.3 lbs (2.4 kg, depending on track gauge)
Product code - 1,435 mm track <i>(other gauges, please contact us)</i>	H80822

RCA

COMBINED TRACK AND TURNOUT GAUGE
FOR CANT AND GAUGE MEASUREMENT

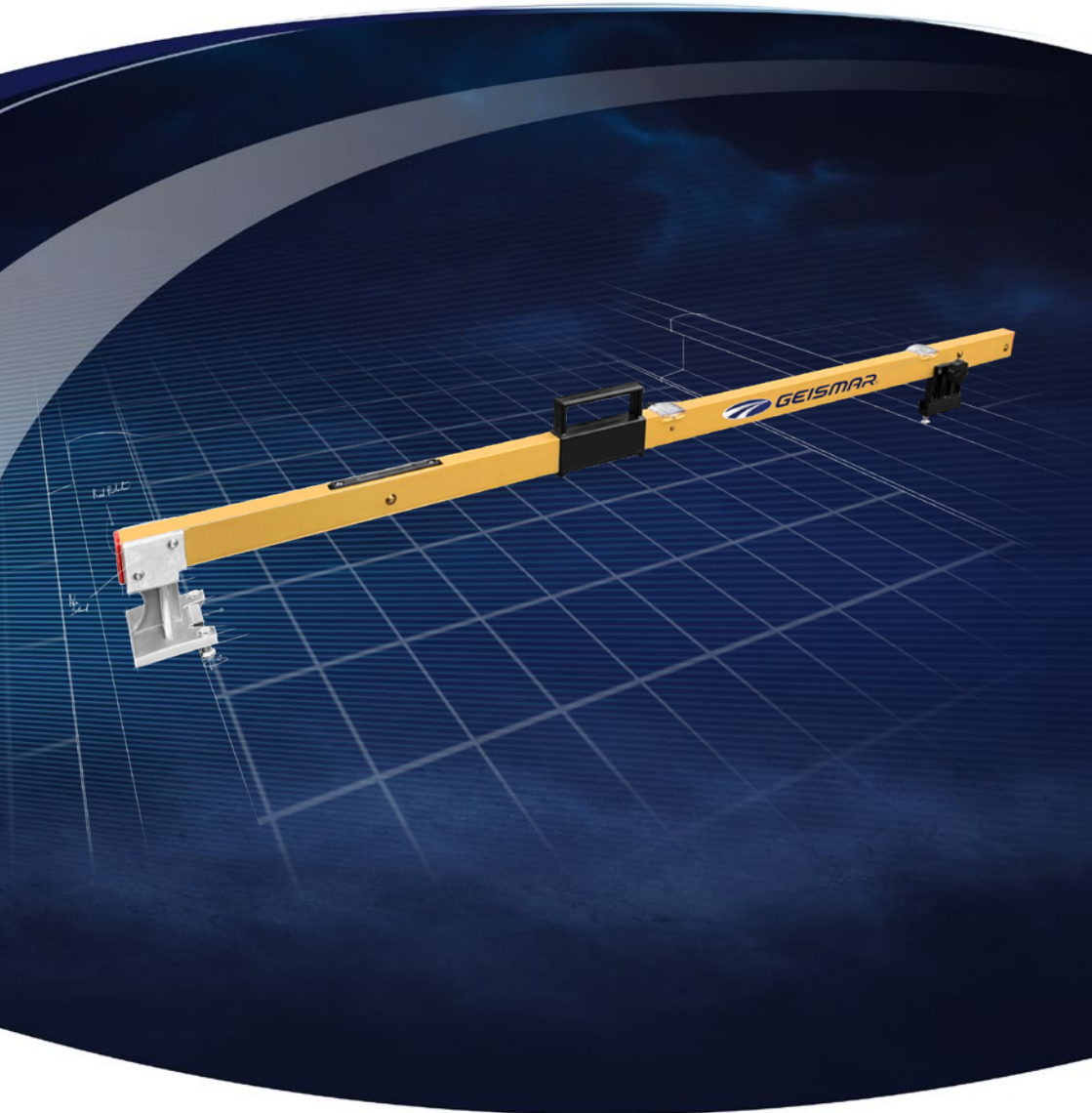

Your benefits

- Static and instantaneous measurement of the track gauge, cross-level, groove width, back-to-back distance and frog nose to check rail
- Robust and lightweight gauge for an intensive use thanks to aluminium square section and the graduated protective screen
- Easy to use for measurement thanks to knurled button and adjusting screws
- Ergonomical thanks to the handle aligned with the gravity centre

Specifications

Product details	Dedicated for plain track and turnouts
Track gauge	Available for all gauges and all types of turnout
Dimensions (L x W x H)	64 x 3.9 x 6.5 in. (1,635 x 100 x 165 mm)
Mass	5.5 lbs (2.5 kg, depending on track gauge)
Product code - 1,435 mm track <i>(other gauges, please contact us)</i>	N00209

garnet-di

DIGITAL TRACK GAUGE FOR TRACK AND SWITCH GEOMETRY MEASUREMENT



Your benefits

- Garnet-DL provides you with precise measurements with a clear display preventing operator misinterpretation
- It is lightweight and very easy to use thanks to a smart interface: the measurements are displayed on the smartphone screen
- You will find this gauge perfect in all circumstances being waterproof, fully insulated and suitable for all types of track even in a 3rd rail environment
- The Garnet-DL version can be connected to a smartphone via Bluetooth, allowing data display and storage for later analysis on a computer

Specifications

Display	16 x 2 characters LCD screen and on the smartphone screen for Garnet-DL
Measurements	Gauge, cross-level, twist, rail/opposite check-rail, flangeway clearance, switchblade opening, back-to-back check-rail
Autonomy	200 h without backlighting
Connectivity	Bluetooth for Garnet-DL versions
Operating temperature	14°F to 122°F (-10°C to +50°C)
Gauge	Available for all gauges
Mass	6.6 lbs (3 kg)
Product code - 1,435 mm track (other gauges, please contact us)	- N06689 - With smartphone and Bluetooth connectivity - N06690 - Bluetooth connectivity - N07120 - Gauge only



MANUAL TRACK RECORDING UNIT

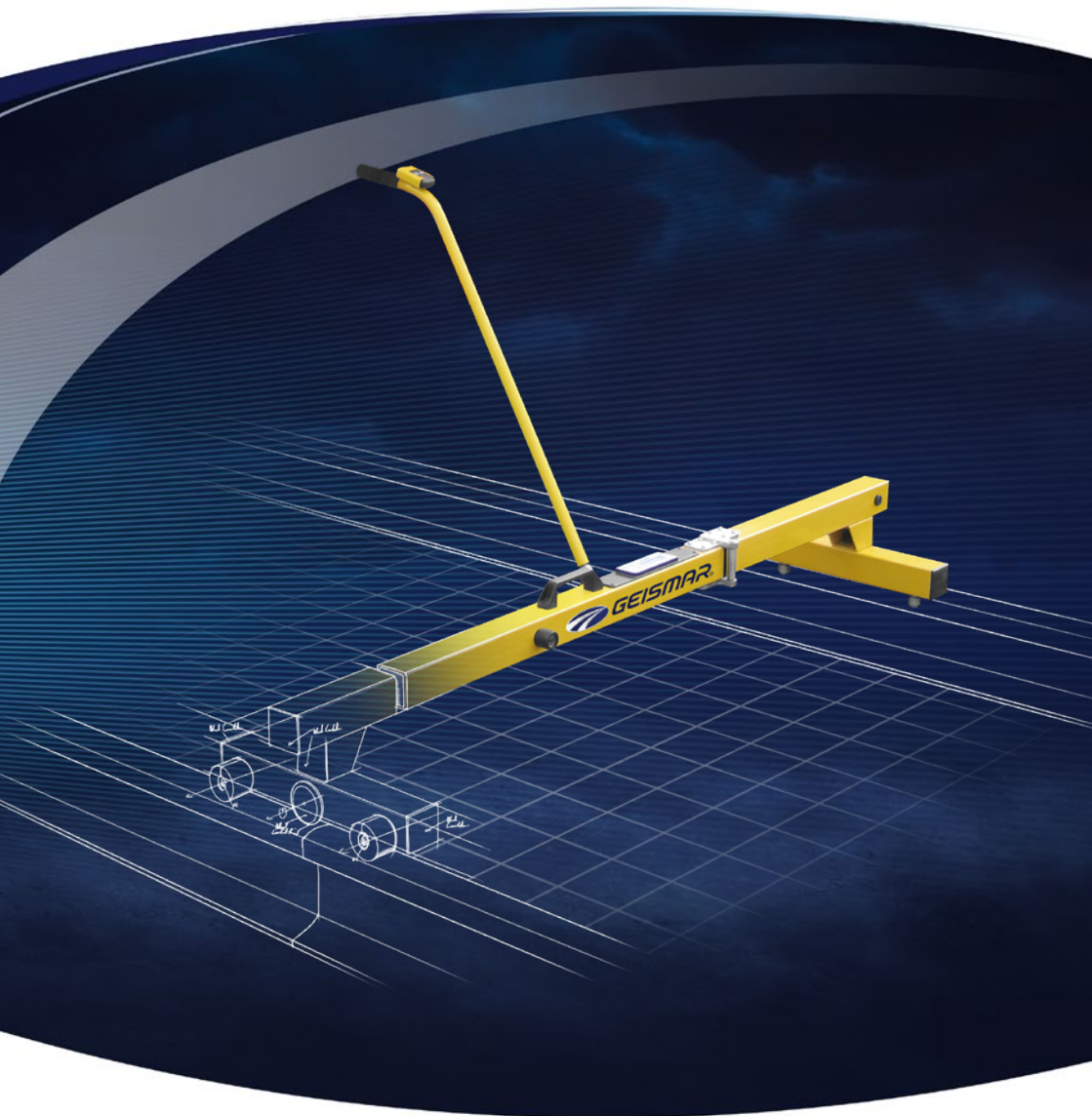

Your benefits

- Robust and lightweight, the trolley is manufactured from glass reinforced plastic (GRP) and is designed to assure you of accurate and reliable measurements
- You will find it extremely simple to set up, the folding mechanism provides ease of transport
- Display and storage of accurate measurements on intuitive and easy to use smartphone connected by Bluetooth allows you efficient data management

Specifications

Display	All measurements are displayed on the smartphone
Measurements	Gauge, cross-level, twist, speed, distance
Contact point	0.6 in. (14 mm) below rail running surface
Autonomy	40 hours
Operating temperature	23°F to 122°F (-5°C to +50°C)
Gauge	Available for all gauges
Mass	≈ 29 lbs (≈ 13 kg)
Product code - 1,435 mm track (other gauges, please contact us)	N06287 (carrying case and smartphone included)



TRACK GEOMETRY AND VERSINE MEASURING
AND RECORDING TROLLEY

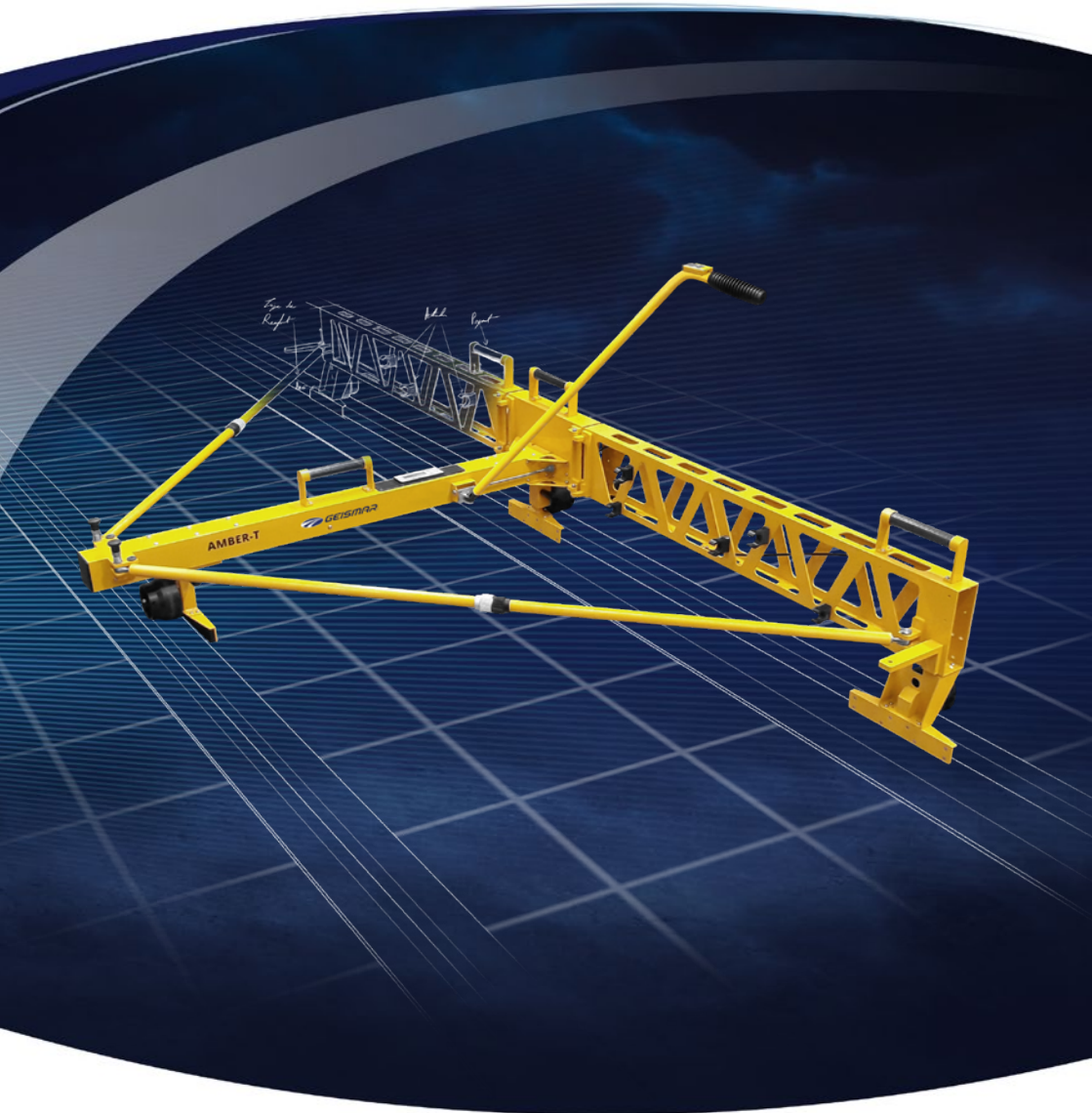

Your benefits

- AMBER-T trolley provides real-time measuring and displaying of all track geometry parameters on smartphone; stored, they can be processed thereafter on a PC
- To maintain conformity to the local track standards: gauge, cross-level, twist, alignment, distance... Data is collected at variable and adjustable sample rates
- Due to its lightweight and ergonomic aluminium design, the track geometry trolley can be folded up in just a few steps for easy transportation to the worksite and quickly assembled on track
- Its 8 ft. (2.5 m) arm ensures accurate alignment measurements and has great autonomy

Specifications

Display	All measurements are displayed on the smartphone
Measurements	Gauge, cross-level, twist, horizontal and vertical alignment, distance, curve radius
Contact point	0.6 in. (14 mm) below rail running surface
Minimum curve radius	82 ft. (25 m)
Gauge	Available for all gauges
Autonomy	> 10 hours
Operating temperature	23°F to 122°F (-5°C to +50°C)
Mass	49 lbs (22 kg)
Product code - 1,435 mm track <i>(other gauges, please contact us)</i>	H124580 (carrying case and smartphone included)



TRACK GEOMETRY AND VERSINE DIGITAL
MEASURING AND RECORDING TROLLEY

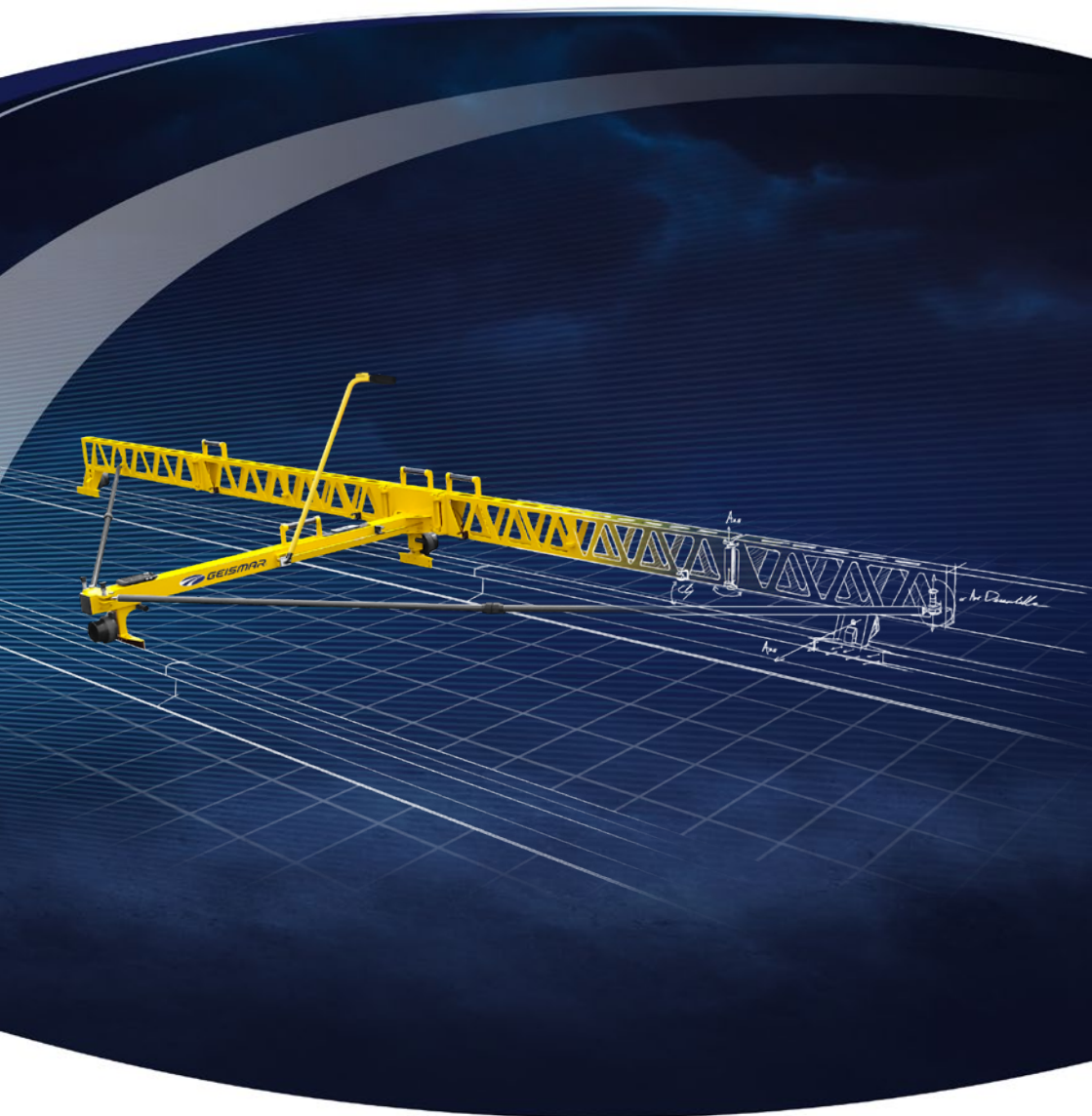

Your benefits

- Light and portable, the track geometry trolley can be easily folded for carrying to site and is quick and easy to set up on track
- The TOPAZ enables the collection and display of all track geometry data and stores it on a smartphone linked to the Topaz via a Bluetooth connection
- The TOPAZ offers you the advantage of continuous data collection of all parameters at variable sample rates to maintain conformity with the local track standards

Specifications

Display	All measurements are displayed on the smartphone
Measurements	Gauge, cross-level, twist, horizontal & vertical alignment, distance
Contact point	0.6 in. (14 mm) below rail running surface
Minimum curve radius	295 ft. (90 m)
Track gauge	Available for all gauges
Autonomy	> 10 hours
Operating temperature	23°F to 122°F (-5°C to +50°C)
Mass	57.3 lbs (26 kg)
Product code - 1,435 mm track <i>(other gauges, please contact us)</i>	H124634 (carrying case and smartphone included)

diamond-s2

PORTABLE TRACK GEOMETRY & SWITCH GEOMETRY
DIGITAL MEASURING AND RECORDING TROLLEY



Your benefits

- The Diamond-S2 trolley offers you a fully portable track geometry recording system
- The laser system determines the exact measuring point on the rail and the onboard GPS function determines the exact track location
- The integrated touch screen computer is convenient and operator friendly. The built-in hard drive collects and stores all data for you to transfer it to another PC using a USB port
- The trolley together with the PC can be folded for storage in a convenient transport case. Due to its light weight, the trolley can be carried by 1 person and set up for operation within 2 minutes

Specifications

Display	All measurements are displayed on a high-brightness PC screen
Measurements	Track gauge, cant, left, two dimension set between the rail and the guard rail, and between the switchblade and the stock rail, distance
Contact point	0.6 in. (14 mm) below rail running surface
Autonomy	> 8 hours
Gauge	Available for all gauges
Operating temperature	23°F to 122°F (-5°C to +50°C)
Mass	57.3 lbs (25 kg)
Product code - 1,435 mm track <i>(other gauges, please contact us)</i>	N07109 (carrying case included)



TOWED TRACK RECORDING UNIT

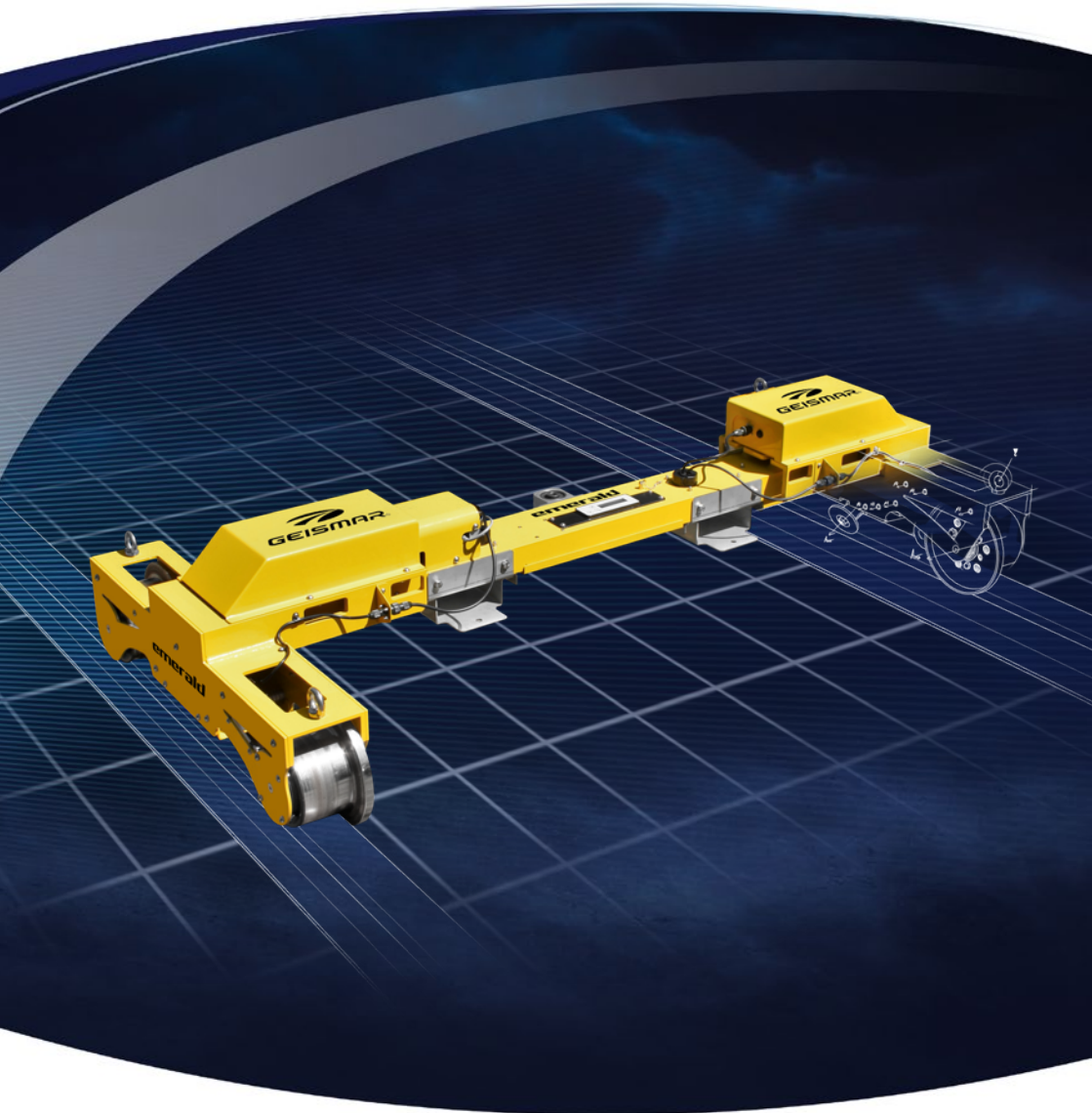

Your benefits

- The towed track recording unit is designed to measure the geometric parameters of the track towed either by road-rail vehicle or an inspection lorry at speeds up to 12 mph (20 km/h). The concept of the trolley makes it easy to pass through switches and crossings
- The EMERALD allows you to save time by intervening closer to your worksites with a road-rail vehicle and to work continuously over long distances with its high capacity data storage
- The display and recording of accurate geolocated measurements on the tablet enables intuitive operation. In addition, data is managed efficiently as the tablet is connected to the trolley by wireless technology
- Its simple, robust and ergonomic design allows a single person to deploy it on site thanks to a Forklift pocket system

Specifications

Measurements	Gauge, cant, twist, warp, travelled distance, speed and GPS location
Measuring speed	12 mph (20 km/h) max
Accuracy	0.04 in. (1 mm) depending on speed
Display	All measurements are displayed on a 7 in. (18 cm) high-resolution tablet
Contact point	0.6 in. (14 mm) below rail running surface
Autonomy	8 hours
Operating temperatures	41°F to 122°F (5°C to +50°C)
Gauge	Available for all gauges
Dimensions (L x W x H)	64 x 30 x 13 in. (1,627 x 750 x 321 mm) for 1,435 mm track
Mass	≈ 139 lbs (≈ 63 kg)
Product code - 1,435 mm track <i>(other gauges, please contact us)</i>	N07552 (smartphone included)

opal mini

LASER ALIGNMENT SYSTEM

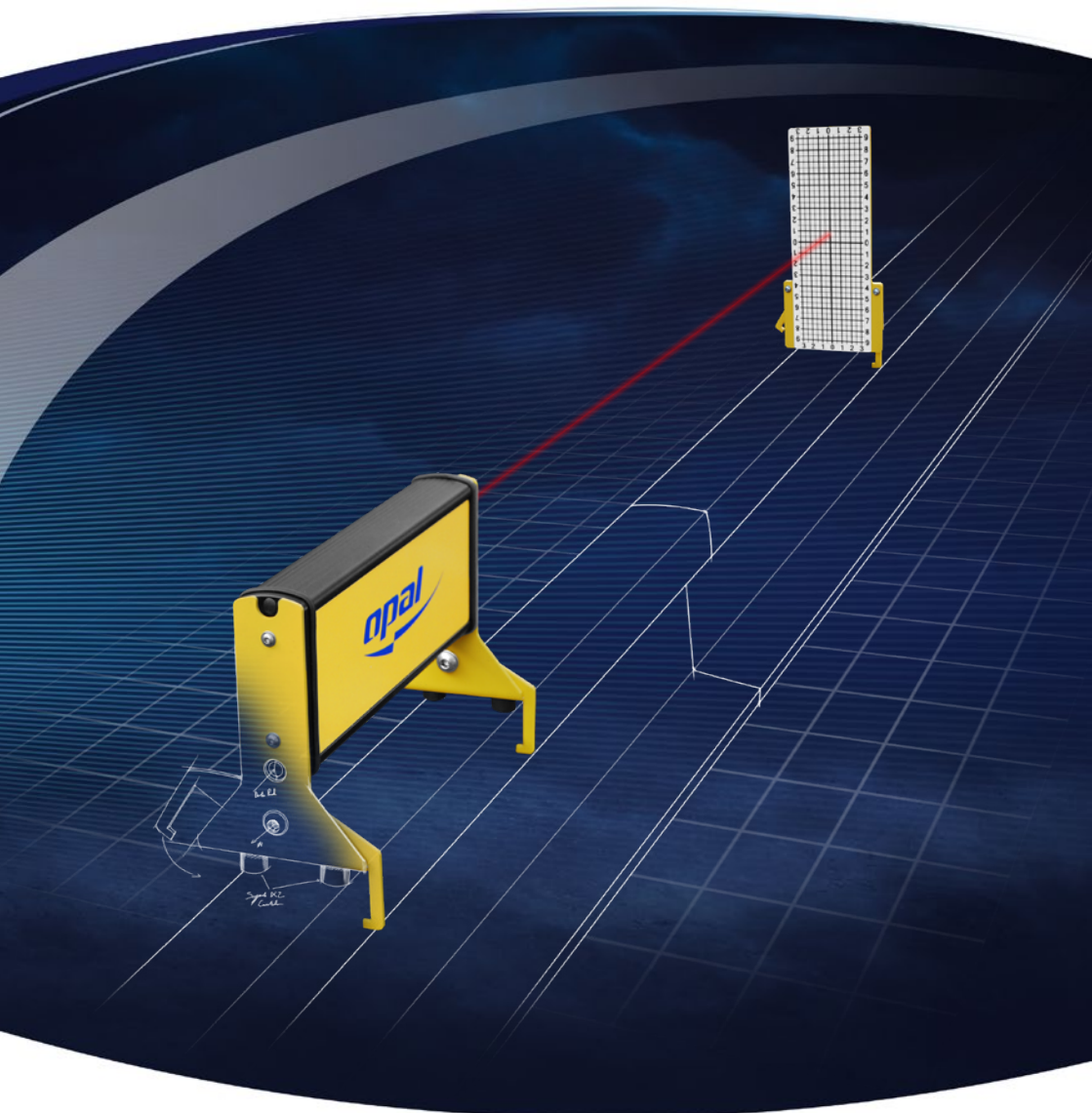

Your benefits

- Very compact device easily transportable in a dedicated protective case
- The laser measuring system is very convenient, lightweight and makes it easy for you to set up in a few seconds
- Bubble levels are fitted to each sub-assembly ensuring complete horizontality before measurement (regardless of rail angle) for perfect accuracy

Specifications

Target size	H = ± 8 in. (200 mm) V = ± 4 in. (90 mm)
Measurements	Horizontal and vertical Versine
Autonomy	100 hours
Operating temperature	14°F to 122°F (-10°C to +50°C)
Laser source mass	4 lbs (2 kg)
Laser target mass	2 lbs (1 kg)
Product code - 1,435 mm track <i>(other gauges, please contact us)</i>	N06979 (smartphone included)

rectirail dl2

PORTABLE ELECTRONIC STRAIGHTNESS MEASURER



Your benefits

- The Rectirail DL2 provides you with an easy and reliable way to measure rail head straightness
- Using the ergonomic joystick and two control buttons on its frame, it offers you a simple way to acquire and store data
- Connected by bluetooth to an Android GPS-enabled rugged smartphone, the data displayed & stored on the device can be easily transferred to a PC for later analysis
- Two magnetic pins allow you to perfectly position the unit on the rail allowing the 100 sensors (over a 1 metre base) to provide accurate measurements at the push of a button

Specifications

Display	All measurements are displayed on the smartphone
Measurements	1 sample every 0.4 in. (10 mm) 100 sensors over a one meter base
Accuracy	$\pm 12.5 \mu\text{m}$
Autonomy	> 8 hours
Operating temperature	32°F to 113°F (0°C à +45°C)
Mass	5 kg
Product code - 1,435 mm track (other gauges, please contact us)	N06644 (smartphone included)



RAIL INCLINATION GAUGE

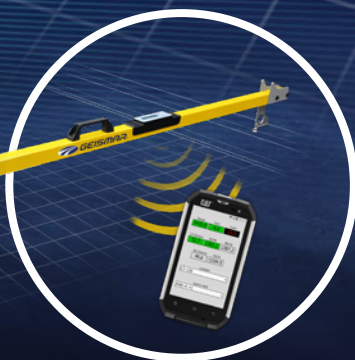
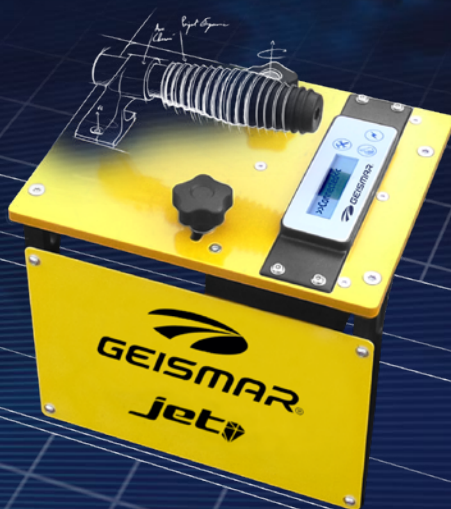

Garnet-DL
Digital track gauge for track and
switch geometry measurement



Your benefits

- JET offers you a safe, simple and ergonomic method to accurately measure rail inclination
- Lightweight and easy to set up on the rail and used by a single operator
- The accuracy is guaranteed by a powerful microcontroller and by means of the adjustments allowing a perfect device positioning
- Data transfer, through a Bluetooth connection for a full display and storage on a dedicated Android smartphone
- Works in association with the Garnet-DL digital track gauge

Specifications

Display	16 x 2 characters LCD screen
Measurements	Rail inclination
Autonomy	40 hours
Operating temperature	14°F to 122°F (-10°C to +50°C)
Mass	9 lbs (4 kg)
Product code - 1,435 mm track (other gauges, please contact us)	N06845 (compatible with Garnet-DL)

mephisto 

LASER SURVEY RECORDER

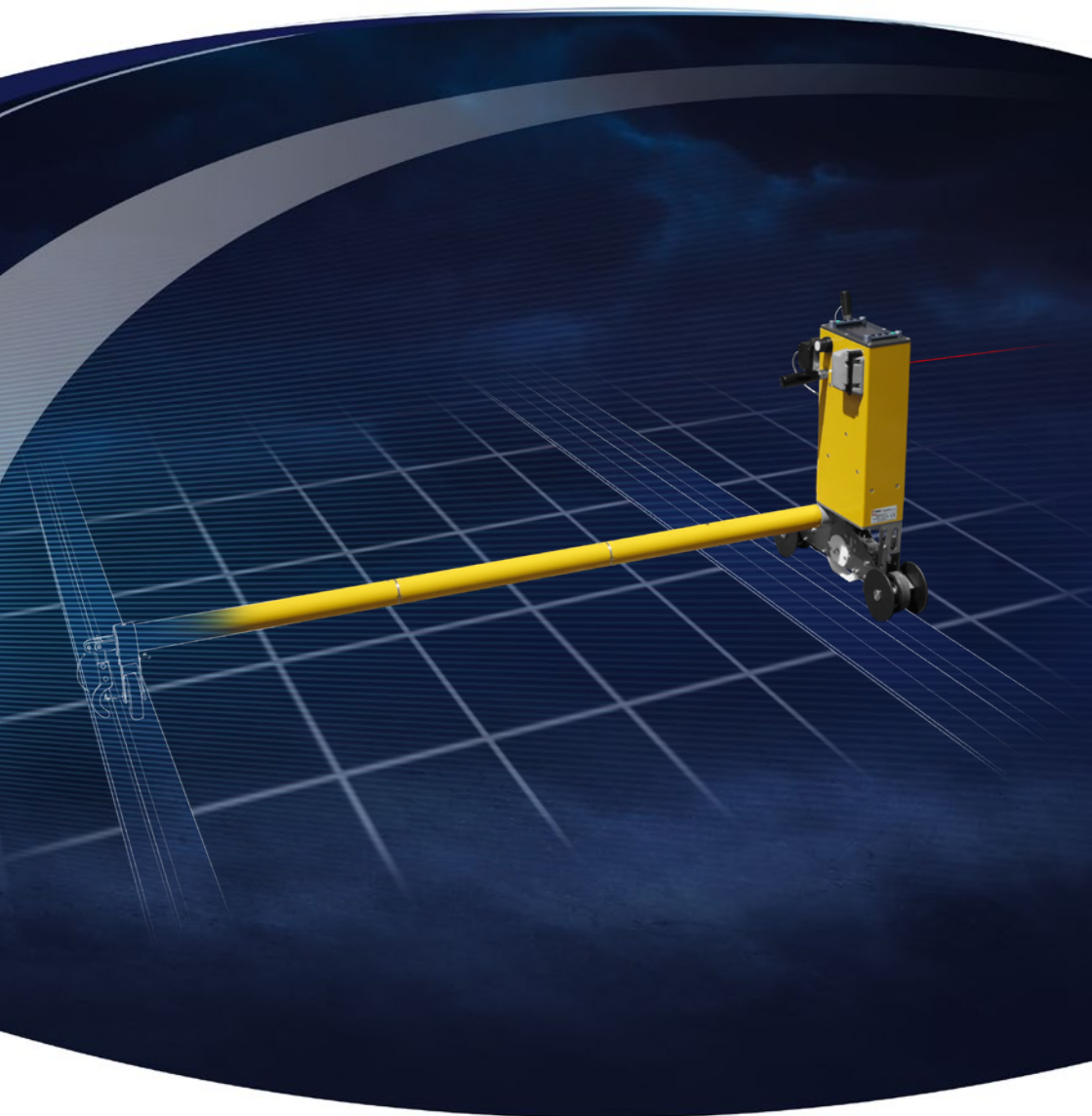

Your benefits

- The Mephisto allows you to obtain precise measurements of the position of the track in relation to benchmarks or fixed installations in order to verify the position of the track. It also makes it possible to measure the position of catenary components. A swivelling laser equipped with a fine adjustment wheel provides this function
- Trolley commands and programs are selectable by an external ergonomic keyboard
- The trolley is composed of light and removable elements that assemble very quickly and are transported in a compact case specially designed for its protection

Specifications

Display	All measurements are displayed on the system screen
Measurements	<ul style="list-style-type: none"> - Position of track (fixed point, low point) - Track structure gauge - Infringements to track structure gauge - Position of reception areas (platform edges, walls) - Bridges curvature - OHL position - Position of the track platform edges - Distance between tracks
Autonomy	> 300 measuring cycles
Operating temperature	23°F to 122°F (-10°C to +50°C)
Mass	< 26 lbs (< 13 kg)
Product code - 1,435 mm track <i>(other gauges, please contact us)</i>	N07535 (carrying case included)

EYE DRAGON



TRACK & CATENARY MEASUREMENT AND VERIFICATION TRACK MOTORCAR



Track geometry
Ballast profile

> The measurement that suits you

The Eye Dragon series of track motorcars guarantees the condition of your track through high-speed recording of all its parameters and surroundings, with minimal traffic interruption.

High versatility through the integration of different measurement systems on demand within a vehicle based on the infrastructure.



OHL inspection
Positioning
Wear
Video recording

Rail geometry
Wear
Ultrasonic inspection



RETROFIT



**GEISMAR
REBORN**



**COMMISSIONING /
TRAINING**



CALIBRATION



RENTAL



**EXTENSION OF
GUARANTEE**



**CERTIFIED
SECOND HAND**



SPARE PARTS



**AFTER-SALES
SERVICE / REPAIR**

From commissioning to spare parts, training and maintenance,
Geismar supports you throughout the life of your machines and projects

 +33 3 69 85 05 05  sav@geismar.com



geismar.com



GEISMAR | +33 1 41 43 40 40 | geismar@geismar.com

Proprietary GEISMAR | April 2023 | We reserve the right to make any alteration or improvement deemed necessary to this equipment. Illustrations may include optional equipment and are not contractual. Performance values are not contractual and binding.