

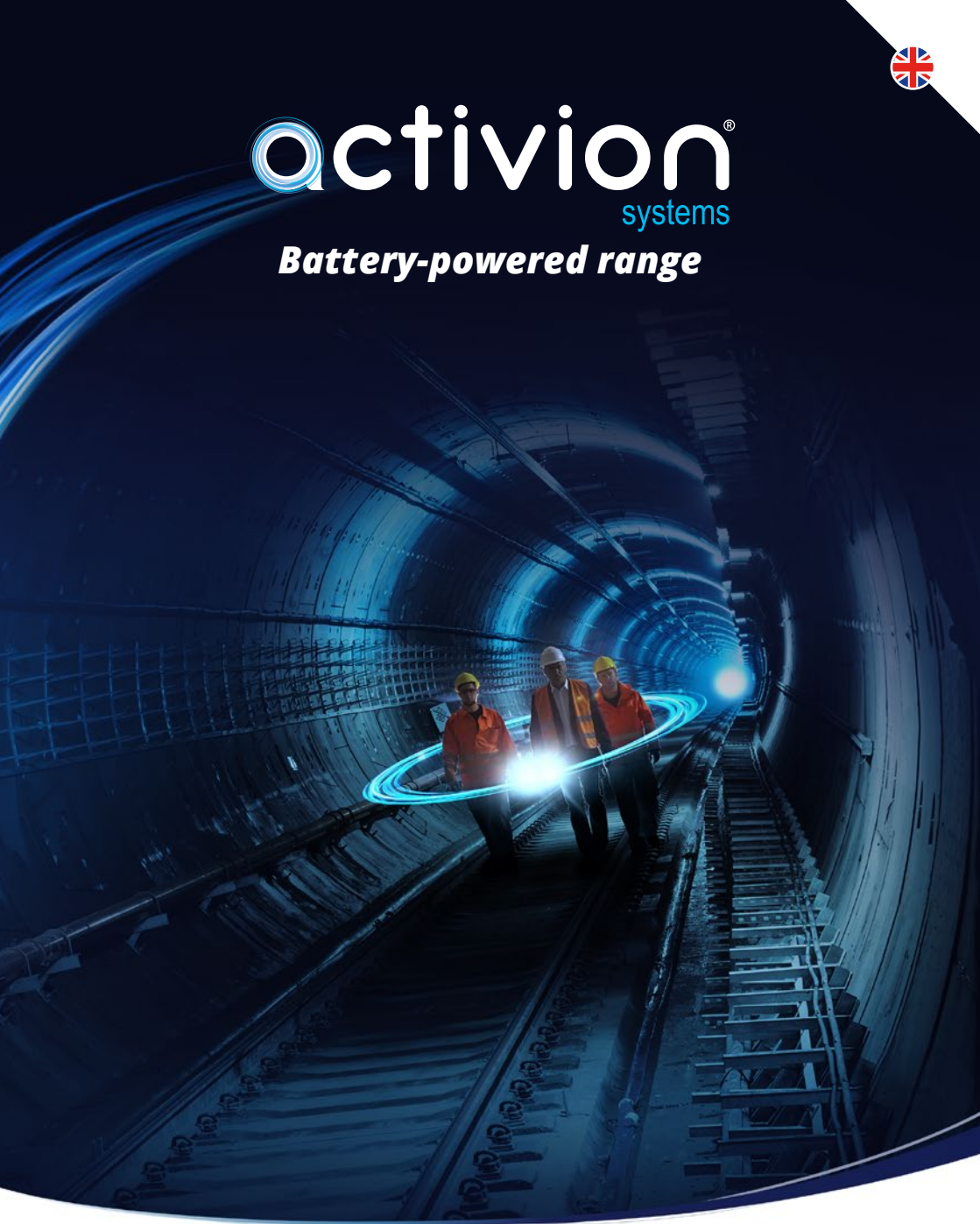

activion[®]
systems

Battery-powered range



GEISMAR[®]
GETS IT DONE

activion® systems

A comprehensive range of electric solutions,
from rolling stock to portable equipment

THE SUSTAINABLE WAY TO RAIL

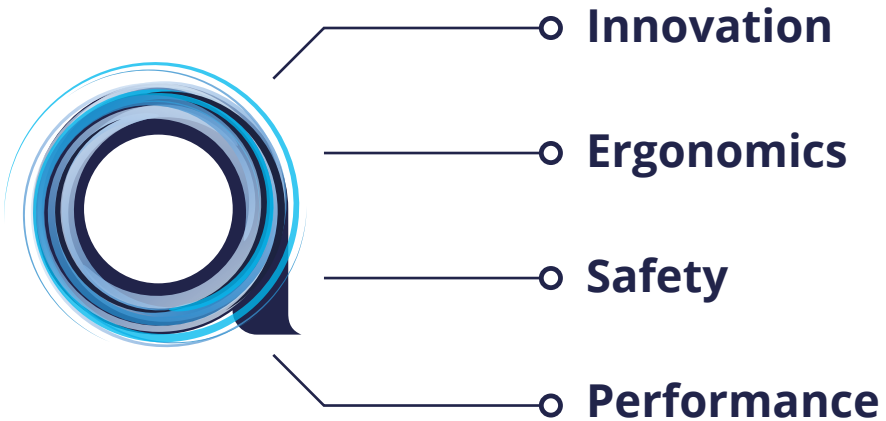

Portable equipment



Handling equipment



Shunting vehicles



activion[®]

systems

Road-rail vehicles



Track motor cars



	<hr/> SHARK 6 <hr/> Abrasive rail saw
	<hr/> NARVAL 8 <hr/> Rail drilling machine*
	<hr/> MANTIS 10 <hr/> Impact wrench*
	<hr/> MORAY 12 <hr/> Portable tamper
	<hr/> MARLIN 14 <hr/> Coachscrewing machine
	<hr/> AGX 16 <hr/> Electric portable equipment conversion kit for coachscrewing machine
	<hr/> BARRACUDA 18 <hr/> Rail profile grinder
	<hr/> AGX 20 <hr/> Electric portable equipment conversion kit for grinder
	<hr/> NAUTILUS 22 <hr/> Hydraulic unit

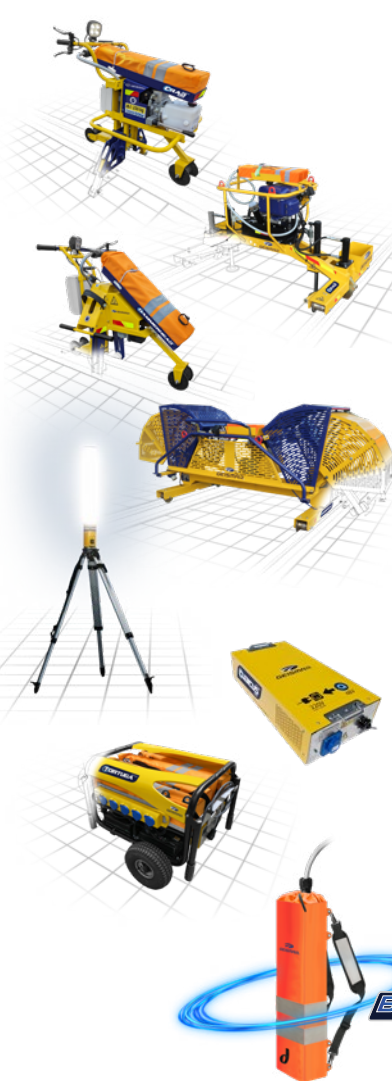

CRAB MOND 24

Single rail lifting trolley

CRAB 26

Rail lifting trolley

HAMMERHEAD MOND 28

Single rail knocker

HAMMERHEAD 30

Rail knocker

NOCTURNA 32

Worksite projector

CUBICUS 34

Converters

TORTUGA 36

Activion power logistics group

BATTERY BACKPACK 38

SHARK

BATTERY-POWERED ABRASIVE RAIL SAW



BATTERY
TECHNOLOGY

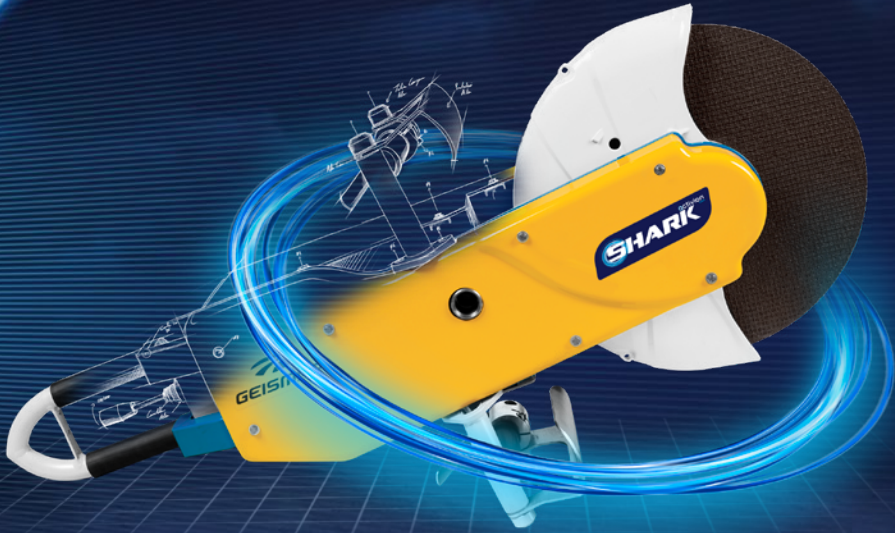

Your benefits

- Efficient rail cutting thanks to the high battery power
- Gas emissions non-existent
- Integrated electronic safety
- Innovative turnaround rail vise allowing to safely cut on both sides without dismounting the machine
- Easier to use and maintain
- Similar work gesture to thermic saws

Specifications

Start	Immediate start with On/Off button
Power maxi	9.5 hp (7 kW)
Cutting time	75-90 s
Mass	46.5 lbs (21 kg)
Sound level	(Laeq) 95 dB(A) (Lwa) 109 dB(A)
Number of cuts with full battery	6 to 8 cuts according to conditions
Dimensions (L x W x H)	38.9 x 13.1 x 17.1 in. (990 x 333 x 435 mm)

NARVAL

BATTERY-POWERED RAIL DRILL

BATTERY
TECHNOLOGY

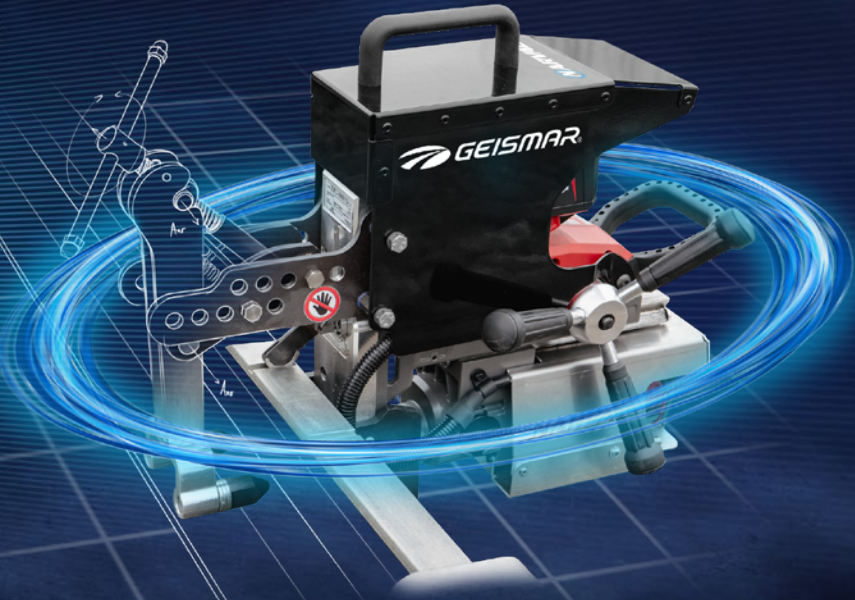

Your benefits

- Battery operated stand-alone rail drilling machine
- Easily transportable due to its low weight of 16.4 kg
- Quick and tool-free installation of Weldon's classic drills with Click and go system
- 2 rotational speeds suitable for drill bits and twist drills
- Drilling up to 40 mm diameter

Specifications

Maximum drilling diameter	1.58 in. (40 mm)
Drilling time	Between 12s and 60s depending on diameter
Max rail hardness standard drills	270 HB (<i>standard drills</i>) 325 HB (<i>premium drills</i>)
Battery capacity	216 Wh
Autonomy	≈ 28 holes of Ø24 mm with one battery
Rotation speeds:	
- Speed for drill bits	400 rpm
- Speed for twist drills	690 rpm
Dimensions in running order (L x W x H)	22.8 x 5.7 x 16.5 in. (580 x 145 x 420 mm)
Mass in working order with battery	36 lbs (16.4 kg)

MANTIS

BATTERY-POWERED IMPACT WRENCH

BATTERY
TECHNOLOGY

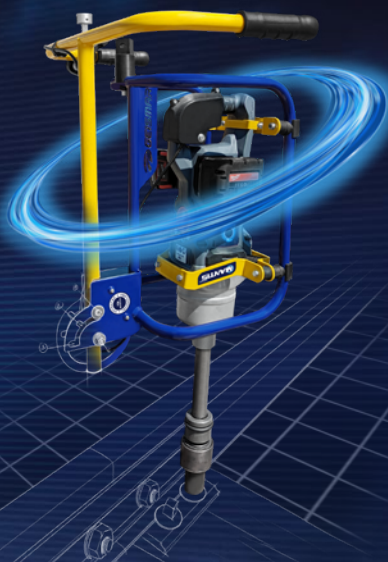
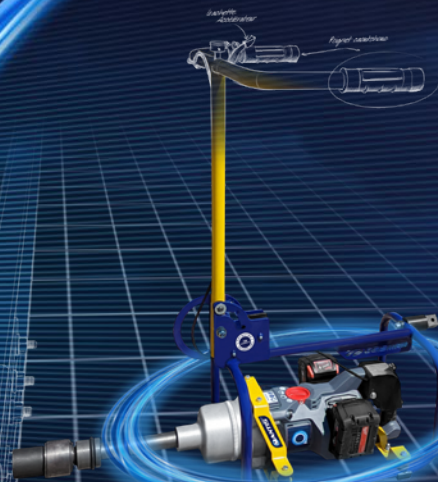

Support trolley
with 3 rollers,
track 1,435 mm



Your benefits

- Driven by a striking mechanism developing up to 4,000 N.m when untightening, the Mantis is simply the most powerful battery-powered railway impact wrench on the market
- Thanks to its proportional throttle, power is delivered precisely and controlled directly by the handle
- Designed for intensive use, the Mantis is built on a patented technology including a shock-absorbing chassis that allows a full day of continuous work
- Activation electric technology for greater ease of use, even in confined or restricted spaces
- Its innovative articulated arm incorporating the main control allows operations to be carried out from a standing position and easy positioning on coachscrews and fishplate bolts
- The rotation direction reversal control featuring a three-position torque limiter is easily accessible whatever the position of the machine, and allows total control of the machine's power

Specifications

Maximum unscrewing torque	4,000 N.m
Adjustable screwing torques	250 / 550 / 3,000 N.m
Output square	1" - 25,4 mm
Tension	36 V (2 x 18 V)
Number of batteries in use	2
Battery capacity	180 Wh (2 x 5 Ah) - 288 Wh (2 x 8 Ah)
Screwing autonomy with torque limiter	288 cycles (2 x 5 Ah) - 450 cycles (2 x 8 Ah)
Unscrewing autonomy at maximum torque	120 cycles (2 x 5 Ah) - 190 cycles (2 x 8 Ah)
Charging time	≈ 2 h
Rotation speeds	500 / 540 / 890 rpm
Hand-arm vibration level	Vertical use 2,6 m/s ² Horizontal use 4,2 m/s ²
Noise level	Lp = 94 dB(A) - Lw = 105 dB(A)
Mass without battery and socket	40.35 lbs (18.3 kg)
Mass in working order	45.2 lbs (20.5 kg) with two 5 Ah batteries 47 lbs (21.3 kg) with two 8 Ah batteries



BATTERY-POWERED PORTABLE TAMPER

BATTERY
TECHNOLOGY



*Ergonomic backpack
handling system (option)*



Your benefits

- Optimal track tamping thanks to the constant vibrations frequency in the ballast
- Engine noise eliminated
- Gas emissions non-existent
- Enhanced performance
- Easier to use and maintain
- Similar work gesture to thermic tampers

Specifications

Start	Immediate start with On/Off button
Maximum tamping power	3.8 kW
Vibration frequency	92 Hz
Mass	47.8 lbs (21.7 kg)
Sound level	(L _{aeq}) 92 dB(A) (L _{wa}) 102 dB(A)
Vibration level	4.6 ms ⁻²
Tamping capacity with full battery	2h according to conditions
Dimensions (L x W x H)	20.6 x 15.3 x 45.3 in. (525 x 390 x 1,090 mm)



BATTERY-POWERED COACHSCREWING MACHINE



BATTERY
TECHNOLOGY

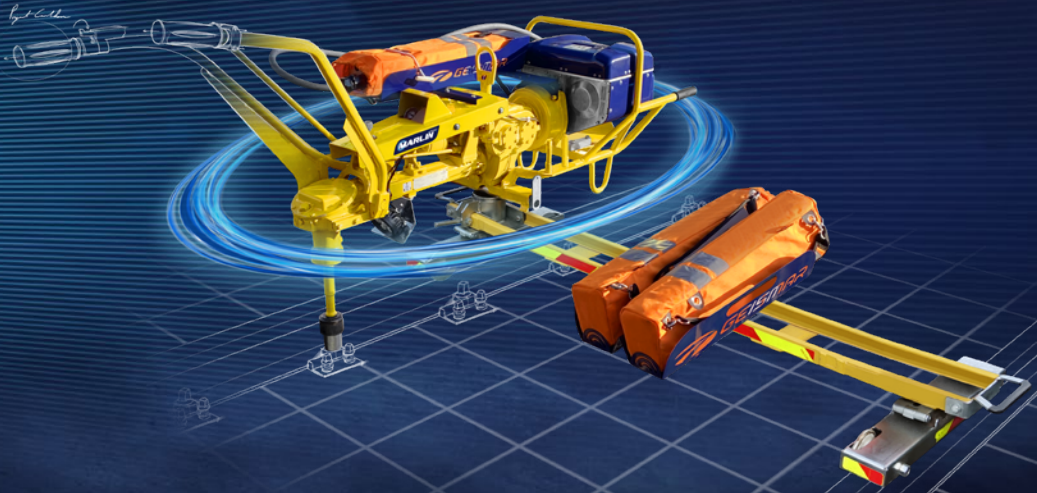

Your benefits

- A battery-powered coachscrewing machine with reliable and site-proven mechanics
- Accurate and high-performance tightening
- 2 rotation speeds
- Easy to use for operators
- 1 to 5 batteries can be carried on the trolley
- Human-Machine Interface (HMI) displaying remaining battery charge and air filter condition

Specifications

Power	6.3 kW
Number of batteries transportable	Up to 5 batteries
Engine	Activion (patented)
Autonomy of 1 Marlin with 1 battery:	
• <i>Tightening</i>	Up to 540 cycles
• <i>Untightening</i>	Up to 900 cycles
Example of worksite with 4 Marlin with 5 batteries each:	
• <i>Tightening</i>	Up to 5,250 ft. (1,600 m)
• <i>Untightening</i>	Up to 8,860 ft. (2,700 m)
Mass without trolley	205 lbs (93 kg)
Mass of trolley without batteries	≈ 77 lbs (35 kg)
Dimension in working order (L x W x H)	80 x 20 x 37 in. (2,030 x 500 x 950 mm)
Maximum tightening torque	60 daN.m
Maximum untightening torque	>100 daN.m
Max. rotation speed	200 rpm

ELECTRIC PORTABLE EQUIPMENT CONVERSION KIT
FOR BOLT HORNET - TC

BATTERY
TECHNOLOGY



Your benefits

- Electric drive retrofit for petrol-powered Bolt Hornet (TC-type) originally equipped with a Honda GX160 or GX200 engine
- Easy fit, no programming needed
- Human-Machine Interface (HMI) displaying remaining battery charge and air filter condition

Specifications

Power	6.3 kW
Autonomy with 1 battery:	
• <i>Tightening</i>	Up to 540 cycles
• <i>Untightening</i>	Up to 900 cycles
Maximum tightening torque	60 daN.m
Maximum untightening torque	>100 daN.m
Max. rotation speed	200 rpm
Dimensions (L x W x H)	80 x 20 x 37 in. (2,030 x 500 x 950 mm)
Mass of the AGX (<i>engine only</i>)	40 lbs (18 kg)
Mass of the machine with AGX (<i>without battery</i>)	About 216 lbs (98 kg)

BARRACUDA

BATTERY-POWERED RAIL PROFILE GRINDER

BATTERY
TECHNOLOGY



Your benefits

- Precise grinding after rail welding (or other application requiring reprofiling)
- Easy to use with an exceptional grinding quality
- Optimized work cycles thanks to the high power output
- Polyvalent tool adaptable to a large number of rails (flat-bottom rails, grooved rails, bridge crane rails)
- Human-Machine Interface (HMI) displaying remaining battery charge and air filter condition

Specifications

Engine	Activion (patented)
Autonomy (continuous grinding)	20 min
Power	6.3 kW
Mass (without battery)	150 lbs (68 kg)
Grinding angle (on each side of the rail)	-15° to +90°
Dimensions (L x W x H)	44 x 30 x 35 in. (1,120 x 770 x 900 mm)

**ELECTRIC PORTABLE EQUIPMENT CONVERSION KIT
FOR METAL HORNET - MP12**

BATTERY
TECHNOLOGY



Your benefits

- Electric drive retrofit for all petrol-powered Metal Hornet (MP12-type)
- Easy fit, no programming needed
- Human-Machine Interface (HMI) displaying remaining battery charge and air filter condition

Specifications

Power	6.3 kW
Autonomy with 1 battery	20 min continuous grinding
Tilting range on both sides	From -15° to +90°
Dimensions (L x W x H)	44 x 30 x 31.5 in. (1,120 x 760 x 800 mm)
Mass of the AGX (<i>engine only</i>)	40 lbs (18 kg)
Mass of the machine with AGX (<i>without battery</i>)	About 163 lbs (74 kg)

NAUTILUS

BATTERY-POWERED HYDRAULIC UNIT

BATTERY
TECHNOLOGY

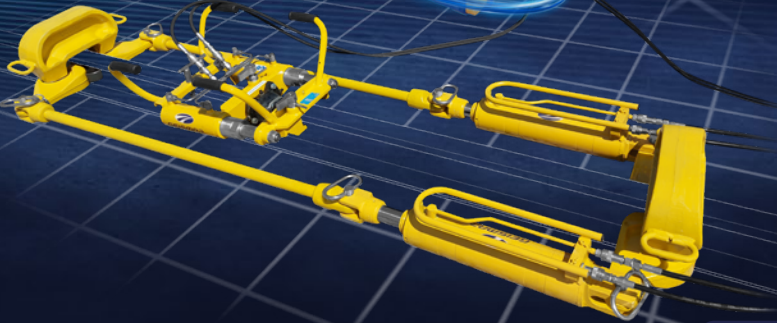

Your benefits

- Compact and powerful, the Nautilus battery-powered hydraulic unit offers a decarbonated solution for rail destressing operations
- Equipped with a dual output, it can feed one rail tensor and one thermite weld shearing machine, or two tensors to work on two lines of rails simultaneously
- Extremely quiet thanks to its battery-powered technology, it can be used on all destressing operation sites, including urban areas and confined spaces
- Brushless electric motor for lighter weight, longer life and reliability
- Equipped with speed control of hydraulic flow for greater precision and ease of use

Specifications

Power	1,500 W
Motor	Brushless
Number of machines that can be connected	2 simultaneously
Hydraulic pressure	From 325 to 700 bars depending on configuration*
Dimensions (L x W x H)	33 x 18 x 18 in. (835 x 445 x 460 mm)
Mass (without battery)	132 lbs (60 kg)

***Configuration:**

Nautilus ESN3 / TH70 VL

Nautilus TH70 VL / TH70 VL

Nautilus TH70 VLA / TH70 VLA

Nautilus TH120 / TH120

Other configurations on request



BATTERY-POWERED SINGLE RAIL LIFTING TROLLEY

BATTERY
TECHNOLOGY



Your benefits

- Rail lifting for base plate replacement or when rollers are positioned for destressing operations
- Ergonomic design for easy on-tracking
- Gas emissions non-existent
- Easier to use and maintain
- Similar work gesture to thermic trolleys

Specifications

Hydroelectric power plant	0,25 cc / 48 V
Power	800 W
Autonomy with 1 battery	1,000 cycles: 1 cycle = <i>tightening</i> , lifting, releasing, <i>untightening</i>
Times for 1 cycle	6 s
Lifting stroke	3 in. (70 mm)
Lifting power	1,300 daN (1.3 tons)
Type of rails	Flat-bottom
Dimensions (L x W x H)	36 x 24 x 32 in. (910 x 600 x 820 mm)
Emergency hand pump	1
Number of clamps per rail	1
Mass (without battery or accessories)	≈ 106 lbs (48 kg)



BATTERY-POWERED RAIL LIFTING TROLLEY

BATTERY
TECHNOLOGY

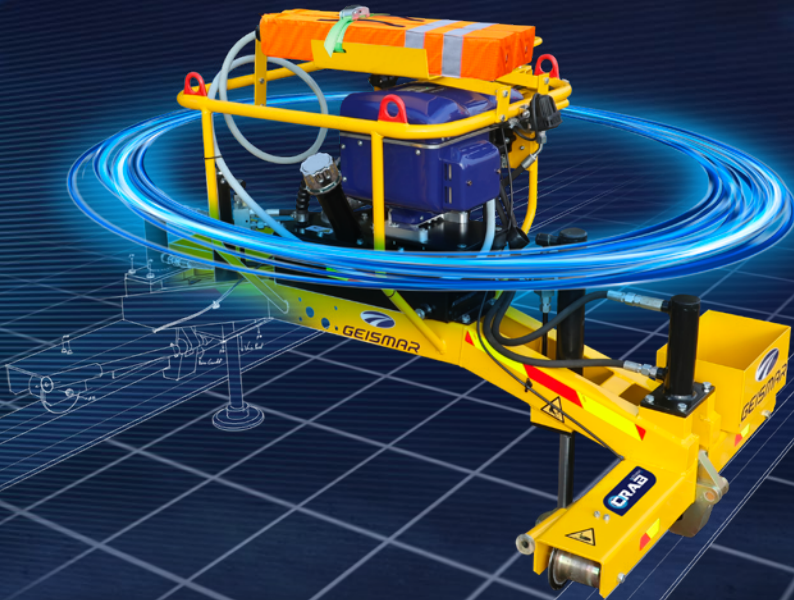

Your benefits

- Rail lifting for base plate replacement or when rollers are positioned for destressing operations
- Ergonomic design for easy on-tracking
- Machine stops thanks to its safe braking system mounted on the handle
- Gas emissions non-existent
- Easier to use and maintain
- Similar work gesture to thermic trolleys

Specifications

Engine	Activion (patented)
Power	6.3 kW
Lifting stroke	12 in. (300 mm)
Clamp cylinder stroke	4 in. (100 mm)
Lifting power	5,500 daN (5.5 tons)
Type of rails	Flat-bottom
Dimensions (L x W x H)	55 x 37 x 35 in. (1,400 x 950 x 900 mm)
Number of clamps per rail	1
Mass (without battery or accessories)	≈ 573 lbs (260 kg)

HAMMERHEAD

MONO

BATTERY-POWERED SINGLE RAIL KNOCKER

BATTERY
TECHNOLOGY



Your benefits

- Rail destressing thanks to double hammers
- Great track mobility thanks to its lightweight chassis
- Hammer heads made of synthetic materials, preserving the rail surface
- Reduced vibration level for longer use time
- Easier to use and maintain
- Similar work gesture to thermic knockers

Specifications

Engine	48 V
Power	220 W
Knocking frequency (per rail)	53 knocks/min
Autonomy with 1 battery	≈ 6 h
Number of rollers	2
Number of hammers	2
Dimensions (L x W x H)	38 x 30 x 35 in. (950 x 760 x 850 mm)
Mass (without battery)	≈ 90.4 lbs (41 kg)

HAMMERHEAD

BATTERY-POWERED RAIL KNOCKER

BATTERY
TECHNOLOGY

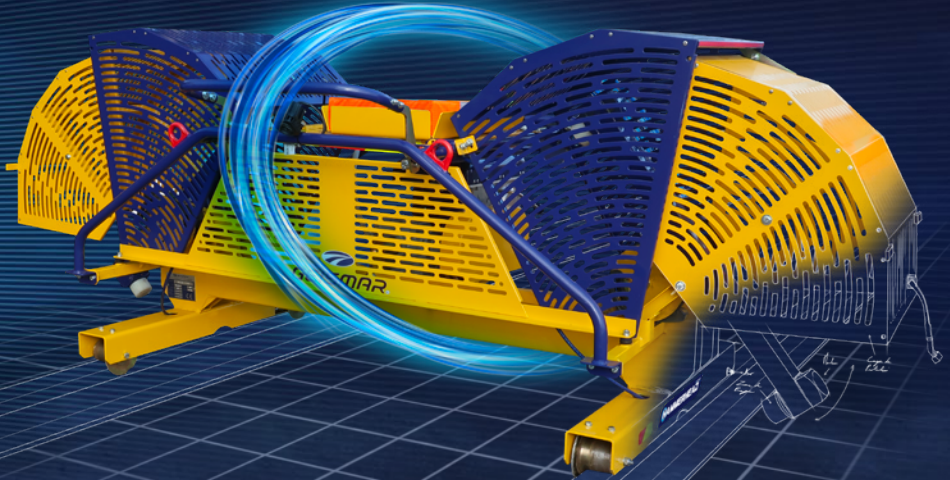

Your benefits

- Rail destressing thanks to double hammers
- Great track mobility thanks to its lightweight chassis
- Hammer heads made of synthetic materials, preserving the rail surface
- Safety for operators with a protective metallic cage and braking system
- Reduced vibration level for longer use time
- Easier to use and maintain
- Similar work gesture to thermic knockers

Specifications

Engine	Activion (patented)
Power	6.3 kW
Knocking frequency (per rail)	48 knocks/min
Number of rollers	4
Number of double hammers	2
Dimensions (L x W x H)	98 x 39 x 39 in. (2,500 x 1,000 x 1,000 mm)
Mass (without battery)	≈ 573 lbs (260 kg)

NOCTURNA

BATTERY-POWERED WORKSITE PROJECTOR

BATTERY
TECHNOLOGY



*Storage box equipped
with an electrical supply*



Your benefits

- Tripod with adjustable height to guaranty stability on any terrain
- Unbreakable polycarbonate tube
- LED lamps for glare-free lighting and long life
- Magnetic lamp base for easy positioning on other supports

Specifications

Number of lights that can be connected in series	Up to 5 per battery
Illumination range	131 to 164 ft. (40 to 50 m)
Illuminance	250 lux at 3.3 ft. (1 m)
Autonomy (for 5 lamps simultaneously)	6h continuously
Dimensions (folded) (L x W x H)	6.7 x 6.7 x 39.4 in. (170 x 170 x 1,200 mm)
Mass (light & tripod)	17.6 lbs (8 kg)



CONVERTERS

BATTERY
TECHNOLOGY

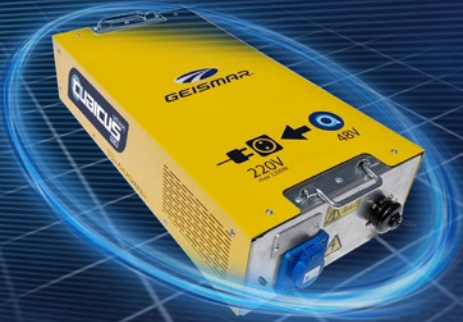

CUBICUS AC



CUBICUS DC

Your benefits

- With CUBICUS AC, take advantage of the long life of the Activion battery on your 220 V equipment or hand-held power tools (up to 3,200W)
- With CUBICUS DC, connect your Activion 48V machines to your 400V three-phase network

Specifications

	CUBICUS AC N08070	CUBICUS DC STE77000Q
Input	48 V DC	400 V three-phase
Output	220 to 240 V AC Single-phase	48 V DC
Output power	Max 3,200 W	7,200 W
Dimensions (L x W x H)	26 x 13.2 x 6.8 in. (660 x 336 x 174 mm)	27.2 x 10.4 x 6.8 in. (690 x 265 x 174 mm)
Mass without cables	30 lbs (13.8 kg)	41.9 lbs (19 kg)
Connectivity Input	Activion	3-pole + earth 32 A
Connectivity Output	<ul style="list-style-type: none"> • 220 V IP54 socket • Multiple Adapters supplied 	Activion
Operating temperatures	-0.4 to 104 °F (-18 to 40°C)	-0.4 to 122°F (-18 to 50°C)
Colour	Yellow RAL 1004	

BATTERY
TECHNOLOGY



Your benefits

- The ideal solution to facilitate battery logistics on site
- Carries up to 7 high-capacity Activion® batteries
- Emission-free generator function: 48 V Activion® output or 220 to 240 V single-phase (up to 3,200 W) to power your equipment
- Multi-charger function for recharging up to 4 Activion® high-capacity batteries and 2 Narval/Mantis batteries
- The modular solution that adapts to your on-site needs and equipment, for easy transport and recharging

Specifications

Battery transport function	Up to 7 batteries
Multi-charger function Number of batteries charged at the same time	4 Activion batteries
Multi-loader input	220 V single-phase 16 A
Generator function Outputs	48 V Activion (with on-board batteries*)
Mass without batteries	70.5 lbs (32 kg)
Dimensions (L x W x H)	29 x 31 x 28.5 in. (738 x 787 x 725 mm)

**not supplied*

BATTERY BACKPACK FOR TRACK MAINTENANCE

Your compact, comfortable and smart work companion



*Battery
charger*



Your benefits

- Backpack battery providing full autonomy and mobility
- One multi-purpose battery for most of portable equipment
- Ideal for confined work environments: tunnels, metros and underground areas
- Adapted to urban works due to reduced sound level
- Battery certified to UN 38.3 transport standard

Specifications

Embedded energy	1,404 Wh
Voltage	46.8 V
Battery capacity	30 Ah
Mass (without carrying system)	21.16 lbs (9.6 kg)
<ul style="list-style-type: none">• <i>Operating temperature</i>• <i>Storage temperature</i>• <i>Charging temperature</i>	<ul style="list-style-type: none">-4 to 104 °F (-20 to +40 °C)-4 to 140 °F (-20 to +60 °C)32 to 122 °F (0 to +50 °C)
Charging time	2h30



RETROFIT



**GEISMAR
REBORN**



**COMMISSIONING /
TRAINING**



CALIBRATION



RENTAL



**EXTENSION OF
GUARANTEE**



**CERTIFIED
SECOND HAND**



SPARE PARTS



**AFTER-SALES
SERVICE / REPAIR**

From commissioning to spare parts, training and maintenance,
Geismar supports you throughout the life of your machines and projects

 +33 3 69 85 05 05  sav@geismar.com



geismar.com

GEISMAR | +33 1 41 43 40 40 | geismar@geismar.com

Proprietary GEISMAR | September 2024 | We reserve the right to make any alteration or improvement deemed necessary to this equipment. Illustrations may include optional equipment and are not contractual. Performance values are not contractual and binding.