

METAL HORNET

MP6 NEO RAIL PROFILE GRINDER

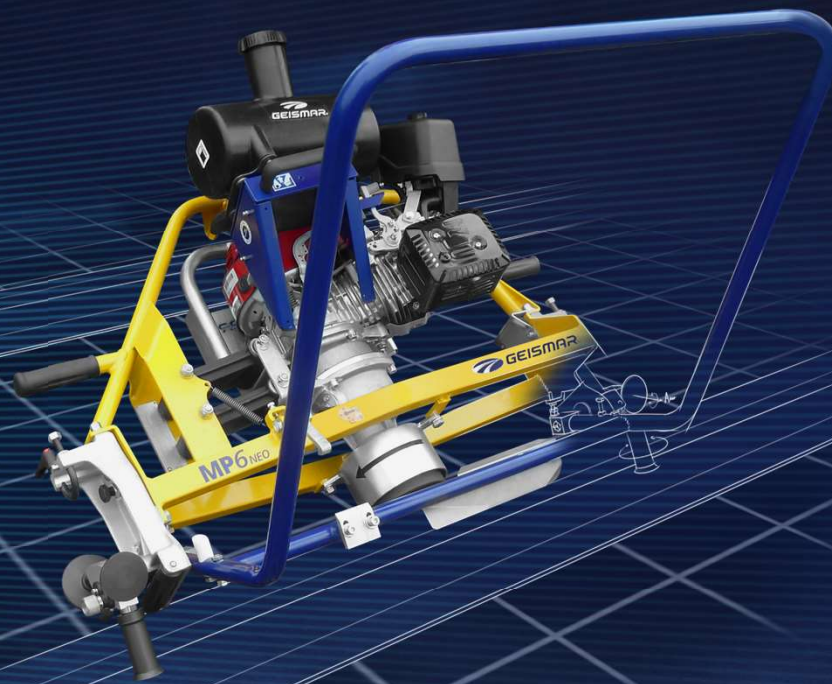

The first rail profile and switch grinder featuring a cyclonic filtration system



*Precise grinding of rails and switches
High-performance Honda GX professional grade engine
Triple cyclonic filter system*

HORNET
PORTABLE TECHNOLOGIES

GEISMAR

Your benefits

- Precise rail grinding after welding
- Option to grind the switch frog by using an extension roller (accessory)
- Quick machine setting for the main email types (Flat bottom, grooved rail, bridge crane...) thanks to the 3 different rollers on the pivoting selector
- Integrated LED lighting directed to the grinding area, increasing comfort and precision



3-position guide rollers

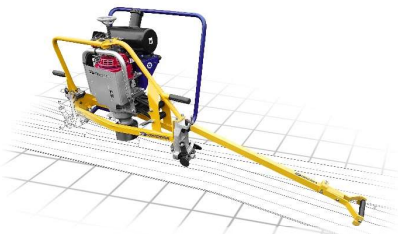

MP6 NEO equipped with extension roller

Standard kit equipment – ST680A03



- Rail profile grinder designed for \varnothing 125 mm grinding wheel
- Hour meter/tachymeter
- LED lighting
- Service tools and user operating manuals

Consumables and accessories

- \varnothing 125mm grindstones - N02780
- Extension roller for switch frog grinding - STK54000F
- Grindstone holder (*several dimensions available*)
- Kickstand - STK54000CW

Grinding tip or grinding plate

Grindstones

	Dimensions	Ref.	
5/8" grindstone holder tip ref. 54015 B For flat bottom rail	\varnothing 80 x 72 mm	N00731	
Grindstone support plate \varnothing 125 - M20 ref. 54015 (factory supplied)	\varnothing 125 x 65 mm	N02780	
Grindstone support plate 4-hole M8 ref. 54059	\varnothing 125 x 60 mm	N00733	

MP6 NEO engine advantages

- Honda 4-stroke professional series engine offering high performances and lower fuel consumption
- Cast iron cylinder sleeve and forged steel crankshaft mounted on ball-bearings for increased durability
- Triple-module cyclonic separation filter maintaining a constant grinding power for longer whist and protecting the engine more efficiently
- Triple filter elements contribute to reducing the maintenance frequency, even in extremely dusty operating conditions

Specifications

Engine	Honda GX200
Engine output	<ul style="list-style-type: none"> • Net power (SAE J1349) = 4.6 kW (5.3 hp) • Gross power (SAE J1995) = 5 kW (6.7 hp)
Engine speed	4,000 rpm
Mass (in working order)	132 lbs (60 kg)
Inclinaison	Up to 90° to the vertical axis
Total stroke of the grindstone	2,6 in. (65 mm)
Dimensions (L x W x H)	42 x 21 x 31 in. (1,060 x 525 x 795 mm)

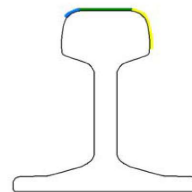
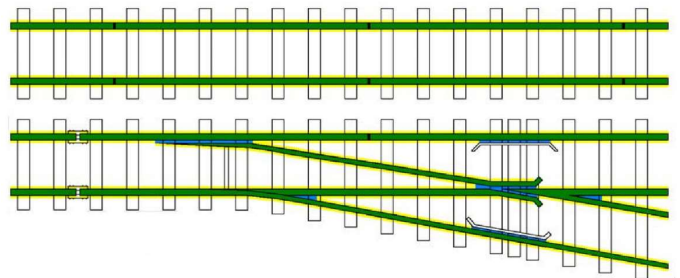

■ corner of rail in grooves (frog points, between rails and check rails, between rails and switchblades)

■ sides of rail elsewhere

■ running surface of rail everywhere

Alternative versions

- Three-phase electric drive 400 V 50 Hz - ST680E50
- Kit without LED lighting - ST680A04