

# DOUBLE HEADED BALLAST TAMPING MODULE

MB2 TL

*A range of accessories  
for all of your works*

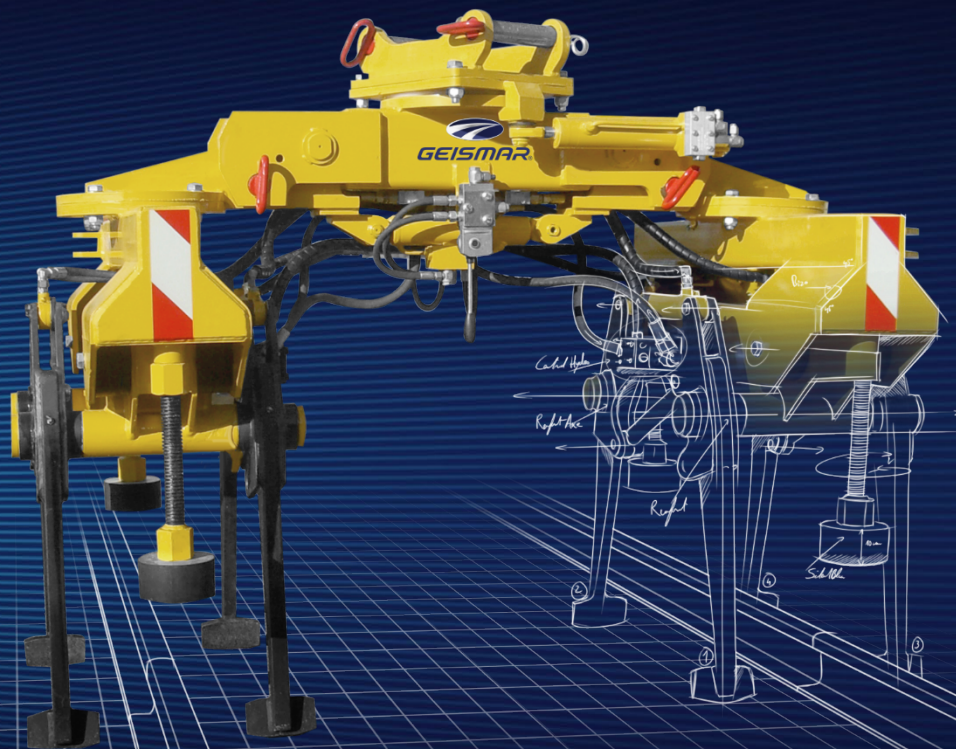

*Stabilization of all track configurations by mechanical tamping*

*High quality and output regarding manual operations*

*Adaptable for any rail loader or excavator*



# DOUBLE HEADED BALLAST TAMPING MODULE

MB2 TL

## Your benefits

- All hydraulic functions are carried out by the excavator operator using joysticks and pedals in the cab
- Lifting of either head is possible for operation in switches and crossings or on single line track
- The diving depth is adjustable and limited by elastic stops

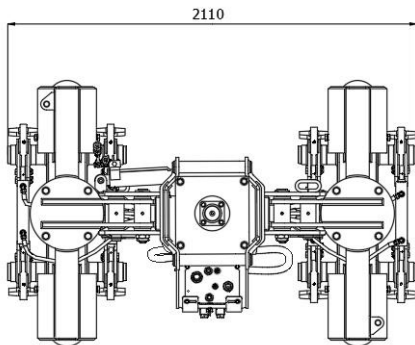
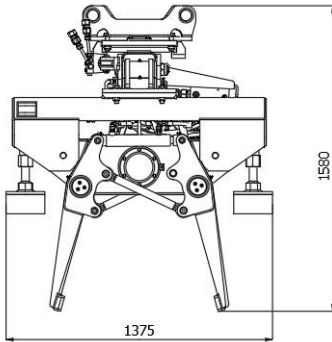
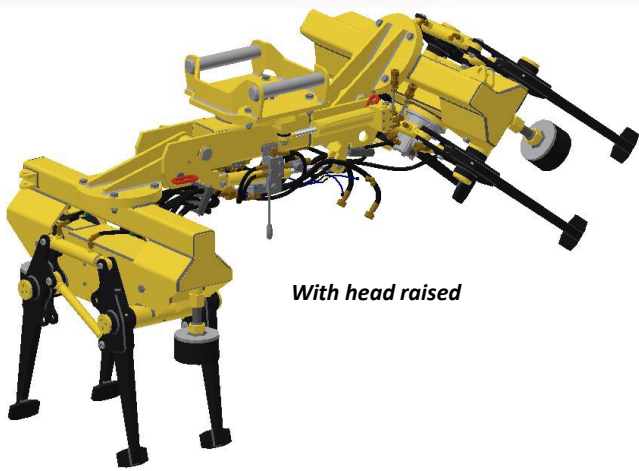

Space

## Specifications

Track gauge	From 1,000 to 1,676 mm (39 to 27 in.) or 1,067 to 1,668 mm (42 to 66 in.)
Dimensions (L x W x H)	2,100 x 1,375 x 1,580 mm (83 x 54 x 62 in.)
Number of heads	2
Hydraulic	150 bars to 105 L/min
Mass	1,450 kg (3,197 lbs)
Output	100 sleepers per hour
Vertical stroke above rail top	500 mm (20 in.)

## Option

- Interface for module transport and handling

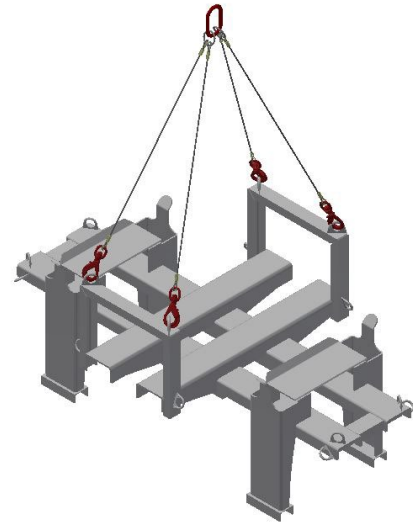

## Accessories for road-rail excavators \*

- Tamping unit MB8 AC
- Sleeper replacer module OST
- Sleeper spacing or rail handing beams PTV / PTC
- Ballast undercutter ODB

\* Non-exhaustive list